

Manually Operated Directional Valves

These valves may be used to manually shift the spool position and change the direction of oil flow.

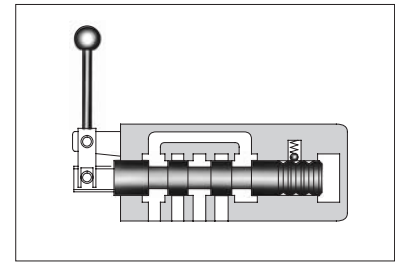
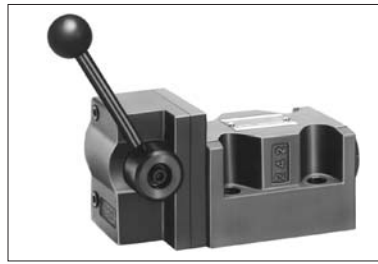

Specifications

Model Numbers	Maximum Flow L/min (U.S.GPM)				Max. Operating Pressure MPa (PSI)	Max. T-Line Back Pressure MPa (PSI)	Approx. Mass kg (lbs.)
	7 MPa (1020 PSI)	14 MPa (2030 PSI)	21 MPa (3050 PSI)	31.5 MPa (4570 PSI)			
Threaded Connections	DMT-03-3C*-50*	100 (26.4) ^{*1}	100 (26.4) ^{*1}	100 (26.4) ^{*1}	25 (3630)	16 (2320)	5.0 (11.0)
	DMT-03-3D*-50*	100 (26.4)	100 (26.4)	100 (26.4)			
	DMT-03-2D*-50*	100 (26.4)	100 (26.4)	100 (26.4)			
	DMT-03-2B*-50*	100 (26.4) ^{*1}	100 (26.4) ^{*1}	100 (26.4) ^{*1}			
	DMT-06*-3C*-30*	300 {200} ^{*2} (79.3 {52.8})	300 {120} ^{*2} (79.3 {31.7})	300 {100} ^{*2} (79.3 {26.4})	21 (3050)	At time spool shift is required: 7 (1020) At time spool shift is not required: 21 (3050)	12.9 (28.5)
	DMT-06*-3D*-30*	300 (79.3)	300 (79.3)	300 (79.3)			
	DMT-06*-2D*-30*	300 (79.3)	300 (79.3)	300 (79.3)			
	DMT-06*-2B*-30*	200 (52.8)	120 (31.7)	100 (26.4)			
	DMT-10*-3C*-30*	500 {315} ^{*2} (132 {83.2})	500 {315} ^{*2} (132 {83.2})	500 {315} ^{*2} (132 {83.2})	21 (3050)	At time spool shift is required: 7 (1020) At time spool shift is not required: 21 (3050)	22 (48.5)
	DMT-10*-3D*-30*	500 (132)	500 (132)	500 (132)			
DMT-10*-2D*-30*	500 (132)	500 (132)	500 (132)				
DMT-10*-2B*-30*	315 (83.2)	315 (83.2)	315 (83.2)				
Sub-Plate Mounting	DMG-01-3C*-10*	35 (9.2)	35 (9.2)	35 (9.2)	25 (3630)	14 (2030) ^{*5}	1.8 (4.0)
	DMG-01-3D*-10*						
	DMG-01-2D*-10*						
	DMG-01-2B*-10*						
	DMG-03-3C*-50*	100 (26.4) ^{*1}	100 (26.4) ^{*1}	100 (26.4) ^{*1}	25 (3630)	16 (2320)	4.0 (8.8)
	DMG-03-3D*-50*	100 (26.4)	100 (26.4)	100 (26.4)			
	DMG-03-2D*-50*	100 (26.4)	100 (26.4)	100 (26.4)			
	DMG-03-2B*-50*	100 (26.4) ^{*1}	100 (26.4) ^{*1}	100 (26.4) ^{*1}			
	DMG-04-3C*-21*	200 (52.8) ^{*3}	200 (52.8) ^{*3}	105 (27.7) ^{*3}	21 (3050)	21 (3050) ^{*6}	7.4 (16.3)
	DMG-04-3D*-21*	200 (52.8)	200 (52.8)	200 (52.8)			
	DMG-04-2D*-21*	200 (52.8)	200 (52.8)	200 (52.8)			
	DMG-04-2B*-21*	90 (23.8)	60 (15.9)	50 (13.2)			
	DMG-06-3C*-50*	500 (132)	500 (132)	500 (132)	31.5 (4570)	21 (3050) ^{*6}	11.5 (25.4)
	DMG-06-3D*-50*	500 (132)	500 (132)	500 (132)			
	DMG-06-2D*-50*	500 (132)	500 (132)	500 (132)			
	DMG-06-2B*-50*	420 (111)	300 (79.3)	250 (66.1)			
	DMG-10-3C*-40*	1100 (291) ^{*4}	1100 (291) ^{*4}	1100 (291) ^{*4}	31.5 (4570)	21 (3050) ^{*6}	48.2 (106)
	DMG-10-3D*-40*	1100 (291)	1100 (291)	1100 (291)			
	DMG-10-2D*-40*	1100 (291)	1100 (291)	1100 (291)			
	DMG-10-2B*-40*	670 (177)	350 (92.5)	260 (68.7)			

Note: The maximum flow means the limited flow without inducing any abnormality to the operation (changeover) of the valve. For details, please refer to the "List of Standard Models and Maximum Flow" on pages 386 to 390.

- ★ 1. Varies depending on the spool type. For details, see the "List of Standard Model and Maximum Flows" for DSG-03 Series Solenoid Operated Directional Valves (page 364 and 366 at 50 Hz rated voltage).
- ★ 2. The figures in parentheses indicate Max. flow for 3C3,3C5, 3C6 and 3C60.
- ★ 3. Varies depending on the spool type. For the details, see the table in the following page.
- ★ 4. Varies depending on the spool type. Same as DSHG-10 (at pilot pressure of 1.5 MPa (220 PSI). See page 390.
- ★ 5. Lever operating torque varies depends on the T-line back pressure. See the right-hand figure.
- ★ 6. If the T-Line back pressure exceeds 7 MPa (1020 PSI), directly connect the drain port to the reservoir.

DMG-01 Lever Operating Torque

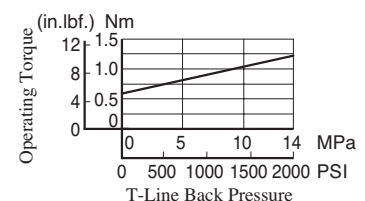

Model Number Designation

F-	DM	T	-03	-2	B	2	A	-50	*	
Special Seals	Series Number	Type of Connection	Valve Size	No. of Valve Position	Spool-Spring Arrangement	Spool Type	Special Two Position Valve	Design Number	Design Standard	
F: Special Seals for Phosphate ester fluids (Omit if not required)	DM: Manually Operated Directional Valves	T: Threaded Connection	03	3	C: Spring Centred	2, 3 4, 40 5, 6 60, 7 8, 9 10, 11 12	A*, B* (Omit if not required)	50	None: Japanese Std. "JIS" 80: European Design Std. 90: N. American Design Std.	
			06 (Piping size 3/4) 06X (Piping size 1)					30		
			10 (Piping size 1-1/4) 10X (Piping size 1-1/2)					30		
			01					10		
			03					50		
		G: Sub-plate Mounting	04	2	D: No-Spring Detented	B: Spring Offset		21	None: Japanese Std. "JIS" and European Design Std. 90: N. American Design Std.	
			06					50		
			10					40		
			See the table below for combinations.							

★ Refer to column "valves using neutral position and side position" (special 2-position valve) on page 431.

Yuken can offer flanged connection valves described below.
Consult us for the details.

Model Numbers	Rated Flow L/min (U.S.GPM)	Max. Operating Pressure MPa (PSI)
DMF-10-***-30*	315 (83.2)	21 (3050)
DMF-16-***-31*	400 (106)	

List of Spool Type

Spool Type	DMG-01			DMT-03 DMG-03			DMT-06* DMT-10*		DMG-04 DMG-06 DMG-10	
	3C 3D	2D	2B	3C 3D	2D	2B	3C 3D	2D	3C 3D	2D
2	○	○	○	○	○	○	○	○	○	○
3	○	○	○	○	—	○	○	○	○	○
4	○	—	—	○	—	—	○	○	○	○
40	○	—	—	○	—	—	○	○	○	○
5	○	—	—	—	—	—	—	—	—	—
6	○	—	—	—	—	—	○	—	○	—
60	○	—	—	○	—	—	—	—	○	—
7	○	○	—	—	—	—	○	○	○	○
8	○	○	○	—	—	—	○	○	○	—
9	○	—	—	○	—	—	○	—	○	—
10	○	—	—	○	—	—	○	—	○	—
11	○	—	—	—	—	—	○	—	○	—
12	○	—	—	○	—	—	○	—	○	—

Maximum Flow of DMG-04-3C*

Model Numbers	Max. Flow L/min (U.S.GPM)		
	7 MPa(1020 PSI)	14 MPa(2030 PSI)	21 MPa(3050 PSI)
DMG-04-3C2	200 (52.8)	130 (34.3)	85 (22.5)
DMG-04-3C3	180 (47.6)	90 (23.8)	70 (18.5)
DMG-04-3C4	200 (52.8)	200 (52.8)	90 (23.8)
DMG-04-3C40	200 (52.8)	200 (52.8)	105 (27.7)
DMG-04-3C5	80 (21.1)	50 (13.2)	40 (10.6)
DMG-04-3C6	90 (23.8)	60 (15.9)	55 (14.5)
DMG-04-3C60	140 (37.0)	70 (18.5)	55 (14.5)
DMG-04-3C7	200 (52.8)	75 (19.8)	55 (14.5)
DMG-04-3C9	200 (52.8)	125 (33.0)	100 (26.4)
DMG-04-3C10	200 (52.8)	130 (34.3)	85 (22.5)
DMG-04-3C11	200 (52.8)	150 (39.6)	85 (22.5)
DMG-04-3C12	200 (52.8)	200 (52.8)	95 (25.1)

Graphic Symbols

Spring Centred Models (3C*)



No-Spring Detented Models

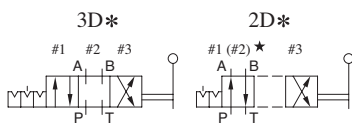

Spring Offset Models (2B*)

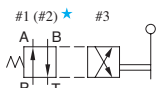

★. Position #2 is applied for models DMG-01-2B* and DM_G^T-03-2B*/2D*.

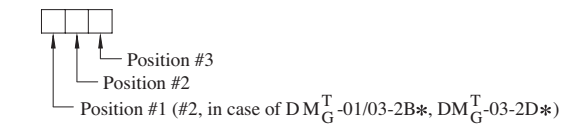

Note: The ○ mark indicate the spool type available for each type.

Valves Using Neutral Position and Side Position (Special Two Position Valve)

In addition to the standard two positions valves (2D*, 2B*), the following two types of two positions valves are available: Valves with neutral position (#2) and position #1 (2B*A, 2D*A), valves with neutral position (#2) and position #3 (2B*B, 2D*B).

The ○ mark in the table below indicates the spool type available for each models.

Spring Offset Models

Valve Type	Graphic Symbols	Model			Valve Type	Graphic Symbols	Model			
		DMT-03 DMG-03	DMT-06* DMT-10*	DMG-04 DMG-06 DMG-10			DMG-01	DMT-03 DMG-03	DMT-06* DMT-10*	DMG-04 DMG-06 DMG-10
2B2A		○	○	○	2B2B		○	○	○	○
2B3A		○	○	○	2B3B		○	○	○	○
2B4A		—	○	○	2B4B		○	○	○	○
2B40A		—	○	○	2B40B		○	—	○	○
—	—	—	—	—	2B5B		○	—	—	—
2B5A		—	○	○			—	—	○	○
2B6A		—	—	○	2B6B		—	—	—	○
		—	○	—			—	—	○	—
2B60A		—	—	○	2B60B		○	○	—	○
		—	○	—			—	—	○	—
2B7A		—	○	○	2B7B		○	—	○	○
2B8A		—	○	—	2B8B		○	—	○	—
2B9A		—	○	○	2B9B		○	—	○	○
2B10A		—	○	○	2B10B		○	○	○	○
2B11A		—	○	○	2B11B		○	—	○	○
2B12A		—	○	○	2B12B		○	○	○	○

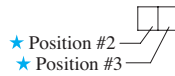
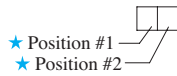

No-spring Detented Models

Valve Type	Graphic Symbols	Model		Valve Type	Graphic Symbols	Model		
		DMT-06* DMT-10*	DMG-04 DMG-06 DMG-10			DMG-01	DMT-06* DMT-10*	DMG-04 DMG-06 DMG-10
2D2A		○	○	2D2B		○	○	○
2D3A		○	○	2D3B		○	○	○
2D4A		○	○	2D4B		○	○	○
2D40A		○	○	2D40B		○	○	○
—	—	—	—	2D5B		○	—	—
2D5A		○	○			—	○	○
2D6A		—	○	2D6B		—	—	○
		○	—			—	○	—
2D60A		—	○	2D60B		○	—	○
		○	—			—	○	—
2D7A		○	○	2D7B		○	○	○
2D8A		○	—	2D8B		○	○	—
2D9A		○	○	2D9B		○	○	○
2D10A		○	○	2D10B		○	○	○
2D11A		○	○	2D11B		○	○	○
2D12A		○	○	2D12B		○	○	○

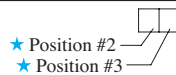
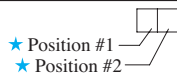

★. Position number is determined with three position type (3C* and 3D*) as the standard.

Sub-plates

Valve Model Numbers	Japanese Standard "JIS"			European Design Standard			N. American Design Standard		
	Sub-plate Model Numbers	Thread Size	Approx. Mass kg (lbs.)	Sub-plate Model Numbers	Thread Size	Approx. Mass kg (lbs.)	Sub-plate Model Numbers	Thread Size	Approx. Mass kg (lbs.)
DMG-01	DSGM-01-31	Rc 1/8	0.8 (1.8)	DSGM-01-3080	1/8 BSPF	0.8 (1.8)	DSGM-01-3190	1/8 NPT	0.8 (1.8)
	DSGM-01X-31	Rc 1/4	0.8 (1.8)	DSGM-01X-3080	1/4 BSPF	0.8 (1.8)	DSGM-01X-3190	1/4 NPT	0.8 (1.8)
	DSGM-01Y-31	Rc 3/8	0.8 (1.8)	—	—	—	DSGM-01Y-3190	3/8 NPT	0.8 (1.8)
DMG-03	DSGM-03-40	Rc 3/8	3.0 (6.6)	DSGM-03-2180	3/8 BSPF	3.0 (6.6)	DSGM-03-2190	3/8 NPT	3.0 (6.6)
	DSGM-03X-40	Rc 1/2	3.0 (6.6)	DSGM-03X-2180	1/2 BSPF	3.0 (6.6)	DSGM-03X-2190	1/2 NPT	3.0 (6.6)
	DSGM-03Y-40	Rc 3/4	4.7 (10.4)	DSGM-03Y-2180	3/4 BSPF	4.7 (10.4)	DSGM-03Y-2190	3/4 NPT	4.7 (10.4)
DMG-04	DHGM-04-20	Rc 1/2	4.4 (9.7)	DHGM-04-2080	1/2 BSPF	4.4 (9.7)	DHGM-04-2090	1/2 NPT	4.4 (9.7)
	DHGM-04X-20	Rc 3/4	4.1 (9.0)	DHGM-04X-2080	3/4 BSPF	4.1 (9.0)	DHGM-04X-2090	3/4 NPT	4.1 (9.0)
DMG-06	DHGM-06-50	Rc 3/4	7.4 (16.3)	DHGM-06-5080	3/4 BSPF	8.5 (18.7)	DHGM-06-5090	3/4 NPT	7.4 (16.3)
	DHGM-06X-50	Rc 1	7.4 (16.3)	DHGM-06X-5080	1 BSPF	8.5 (18.7)	DHGM-06X-5090	1 NPT	7.4 (16.3)
DMG-10	DHGM-10-40	Rc 1-1/4	21.5 (47.4)	DHGM-10-4080	1-1/4 BSPF	21.5 (47.4)	DHGM-10-4090	1-1/4 NPT	21.5 (47.4)
	DHGM-10X-40	Rc 1-1/2	21.5 (47.4)	DHGM-10X-4080	1-1/2 BSPF	21.5 (47.4)	DHGM-10X-4090	1-1/2 NPT	21.5 (47.4)

- Sub-plates are available. Specify the sub-plate model number from the table above. When sub-plates are not used, the mounting surface should have a good machined finish.
- Sharable with Solenoid Operated Directional Valves and Solenoid Controlled Pilot Operated Directional Valves. For dimensions, refer to the right table then see the corresponding pages.

- Sub-plate dimensions appearing page

Subplate Model Numbers	Page
DSGM-01*	356
DSGM-03*	373
DHGM-04*	401
DHGM-06*	402
DHGM-10*	403

Mounting Bolts

Valve Model Numbers	Socket Head Cap Screw			
	Japanese Standard "JIS" European Design Standard	N. American Design Standard	Qty.	Tightening Torque Nm (in. lbs.)
DMG-01	M5 × 45 Lg.	No. 10-24 UNC × 1-3/4 Lg.	4	5-7 (44-62)
DMG-03	M6 × 35 Lg.	1/4-20 UNC × 1-3/4 Lg.	4	12-15 (106-133)
DMG-04	M6 × 40 Lg.	1/4-20 UNC × 1-1/2 Lg.	2	12-15 (106-133)
	M10 × 45 Lg.	3/8-16 UNC × 1-3/4 Lg.	4	58-72 (513-637)
DMG-06	M12 × 60 Lg.	1/2-13 UNC × 2-1/2 Lg.	6	100-123 (885-1089)
DMG-10	M20 × 75 Lg.	3/4-10 UNC × 3 Lg.	8	473-585 (4195-5177)

Instructions

- Avoid connecting the Tank Port "T" to a line with possible surge pressure.

Pressure Drop

The following characteristics are based on the following conditions: viscosity of the fluid: 35 mm²/s (164 SSU) and Specific Gravity: 0.850

- For any other viscosity, multiply the factors in the table below.

Viscosity	mm ² /s	15	20	30	40	50	60	70	80	90	100
	SSU		77	98	141	186	232	278	324	371	417
Factor		0.81	0.87	0.96	1.03	1.09	1.14	1.19	1.23	1.27	1.30

- For any other specific gravity (G'), the pressure drop (ΔP) may be obtained from the formula below.

$\Delta P' = \Delta P (G'/G)$ where, ΔP is a value on the following chart and G is 0.850.

- DMT-06, 06X

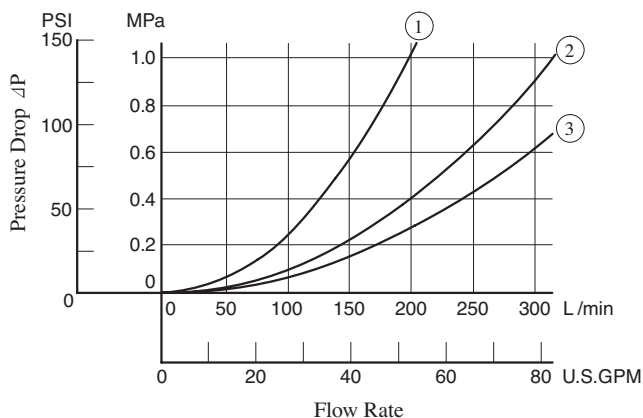

Spool Type	Pressure Drop Curve Number				
	P→A	B→T	P→B	A→T	P→T
2	②	②	②	②	—
3	③	②	③	②	②
4	②	③	②	②	—
40	②	②	②	②	—
5	③	②	②	②	—
6	③	②	③	②	①
60	③	②	③	②	①
7	②	②	②	②	—
8	②	—	②	—	—
9	③	②	③	②	—
10	②	②	②	②	—
11	③	②	②	②	—
12	②	②	②	②	—

● DMT-10, 10X

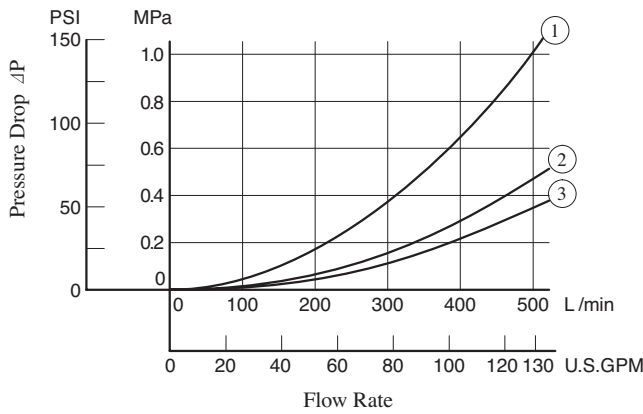

Spool Type	Pressure Drop Curve Number				
	P→A	B→T	P→B	A→T	P→T
2	③	②	③	②	—
3	③	②	③	②	②
4	③	②	③	②	—
40	③	②	③	②	—
5	③	②	③	②	—
6	③	③	③	③	①
60	③	③	③	③	①
7	③	②	③	②	—
8	③	—	③	—	—
9	③	②	③	②	—
10	③	②	③	②	—
11	③	②	③	②	—
12	③	②	③	②	—

● DMG-01

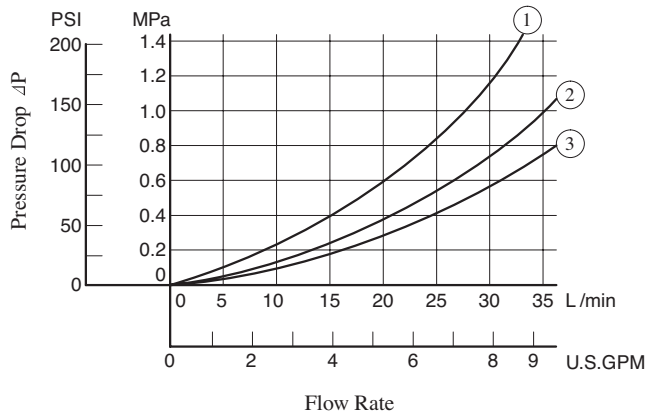

Valve type				Pressure Drop Curve Number				
3C*	3D*	2D*	2B*	P→A	B→T	P→B	A→T	P→T
3C2	3D2	2D2		③	③	③	③	—
3C3	3D3	2D3		③	③	③	③	②
3C4	3D4			③	③	③	③	—
3C40	3D40			③	③	③	③	—
3C5	3D5			②	①	①	①	③
3C60	3D60			①	①	①	①	③
3C7	3D7	2D7		③	③	③	③	—
3C8	3D8	2D8		③	—	③	—	—
3C9	3D9			③	③	③	③	—
3C10	3D10			③	③	③	③	—
3C11	3D11			③	③	③	③	—
3C12	3D12			③	③	③	③	—
			2B2	②	②	③	③	—
			2B3	②	②	③	③	—
			2B8	③	—	③	—	—

● DMG-04

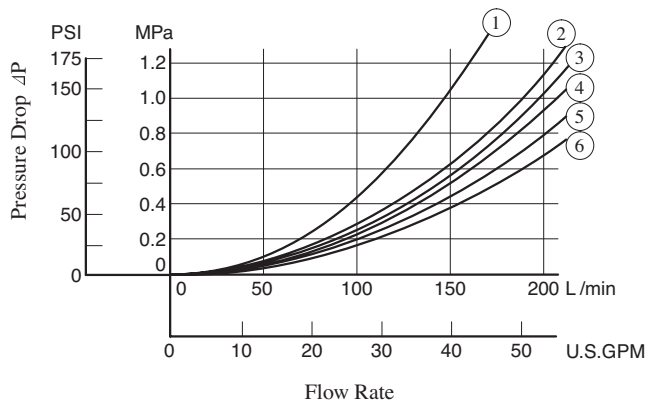

Spool Type	Pressure Drop Curve Number				
	P→A	B→T	P→B	A→T	P→T
2	⑤	②	⑤	④	—
3	⑥	③	⑥	⑤	③
4	⑤	④	⑤	⑤	—
40	⑤	④	⑤	⑤	—
5	⑤	②	④	⑤	①
6	②	③	④	②	①
60	②	③	④	②	①
7	⑤	②	⑤	⑤	—
9	⑥	②	⑥	⑤	—
10	⑤	④	⑤	⑤	—
11	⑤	④	⑤	⑤	—
12	⑤	③	⑤	⑤	—

● For DMT-03, DMG-03, DMG-06, and DMG-10, refer to the table below then see the related page.

Model Number	Pressure Drop Characteristics	Page	Remarks
DMT-03 DMG-03	Same as DSG-03 Series Solenoid Operated Directional Valves (Standard Type)	371	3D* is same as 3C*
DMG-06	Same as Solenoid Controlled Pilot Operated Directional Valves (DSHG-06)	393	
DMG-10	Same as Solenoid Controlled Pilot Operated Directional Valves (DSHG-10)	393	



DMT-03-*-50/5080/5090**

How to Change Lever Position:

The lever position can be changed to any position in five different positions shown on the sketch in the right. For the lever position change, remove the Soc. Hd. Cap Screw and lever once, set the lever at the required position and tighten it with the Soc. Hd. Cap Screw firmly.

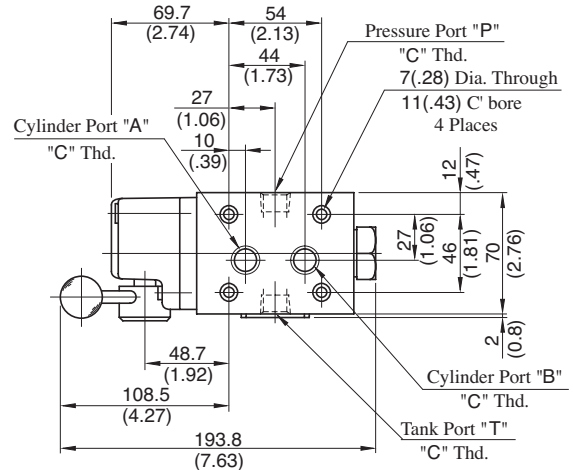
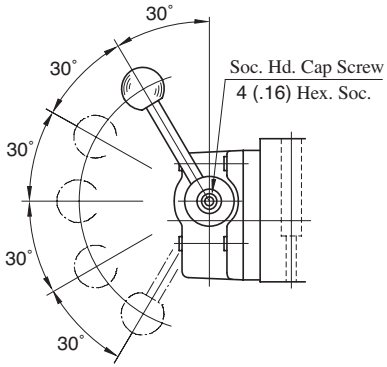

Model Numbers	"C" Thd.
DMT-03-***-50	Rc 3/8
DMT-03-***-5080	3/8 BSPF
DMT-03-***-5090	3/8 NPT

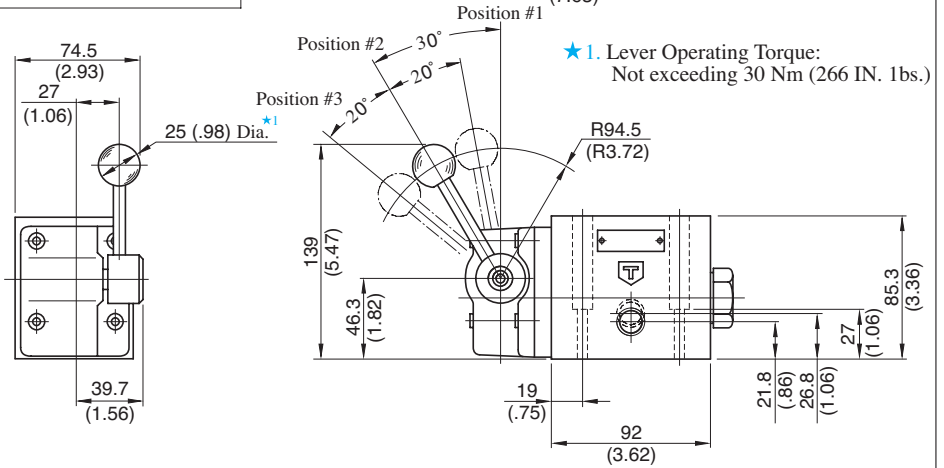

DIMENSIONS IN MILLIMETRES (INCHES)

DMT-06, 06X-*-30/3080/3090**
DMT-10, 10X-*-30/3080/3090**

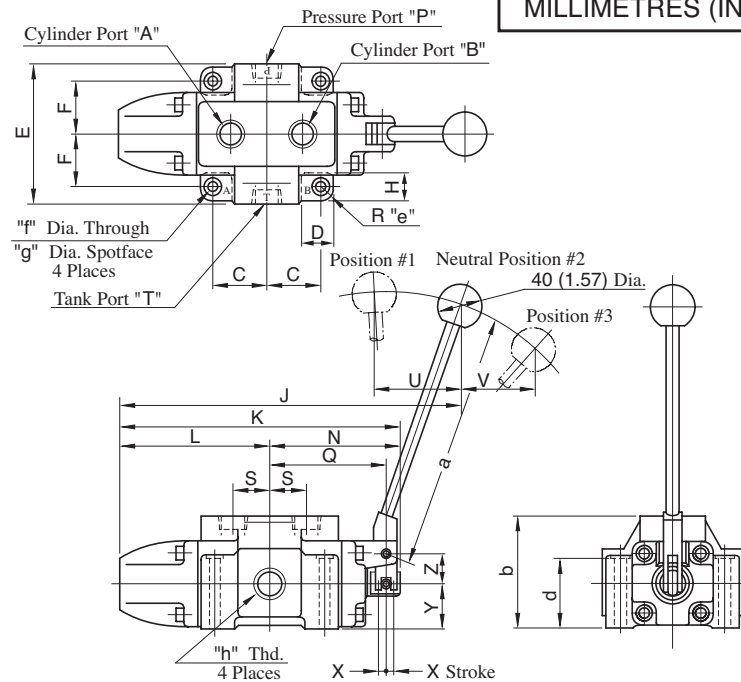

Model Numbers	"h" Thd.
DMT-06-***-30	Rc 3/4
DMT-06X-***-30	Rc 1
DMT-06-***-3080	3/4 BSPF
DMT-06X-***-3080	1 BSPF
DMT-06-***-3090	3/4 NPT
DMT-06X-***-3090	1 NPT
DMT-10-***-30	Rc 1-1/4
DMT-10X-***-30	Rc 1-1/2
DMT-10-***-3080	1-1/4 BSPF
DMT-10X-***-3080	1-1/2 BSPF
DMT-10-***-3090	1-1/4 NPT
DMT-10X-***-3090	1-1/2 NPT

Model No.	Dimension mm (Inches)																					
	C	D	E	F	H	J	K	L	N	Q	S	U	V	X	Y	Z	a	b	d	e	f	g
DMT-06	50	30	126	47.5	24	320	255	137	118	107	33.5	86	76	9	40	25	250	100	63.5	12	11	17.5
DMT-06X	(1.97)	(1.18)	(4.96)	(1.87)	(.94)	(12.60)	(10.04)	(5.39)	(4.65)	(4.21)	(1.32)	(3.39)	(2.99)	(.35)	(1.57)	(.98)	(9.84)	(3.94)	(2.50)	(.47)	(.43)	(.69)
DMT-10	66	40	160	62.5	33	402	320	173	147	135	40	102	90	12.5	50	35	300	120	78.5	15	13.5	21
DMT-10X	(2.60)	(1.57)	(6.30)	(2.46)	(1.30)	(15.83)	(12.60)	(6.81)	(5.79)	(5.31)	(1.57)	(4.02)	(3.54)	(.49)	(1.97)	(1.38)	(11.81)	(4.72)	(3.09)	(.59)	(.53)	(.83)

DMG-01-***-10/1090

Mounting surface: ISO 4401-AB-03-4-A

DIMENSIONS IN
MILLIMETRES (INCHES)

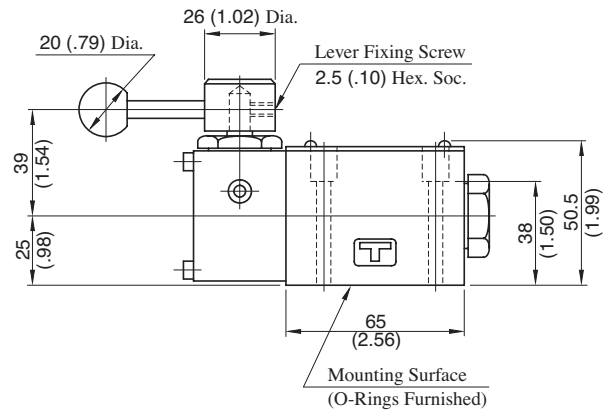
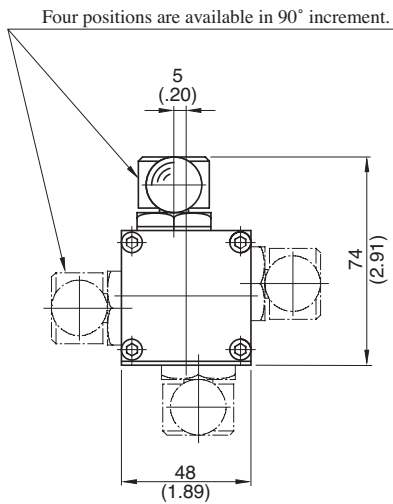
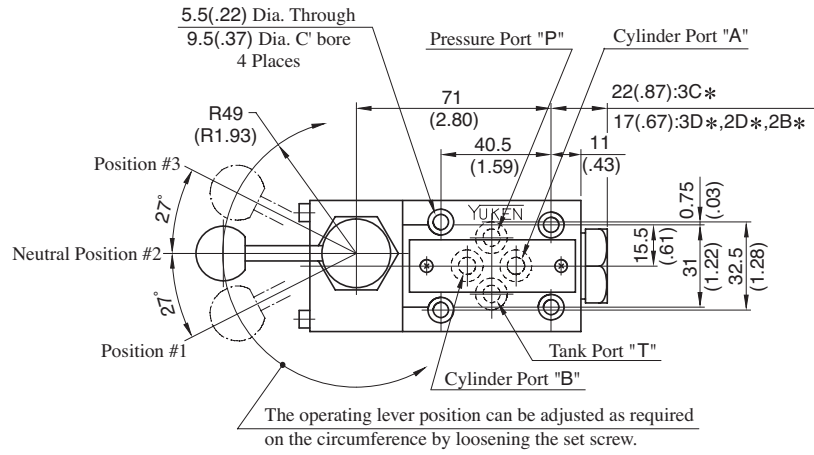

Note: For the valve mounting surface dimensions, see the dimensional drawing of the sharable sub-plate in [page 356](#).



DMG-03-***-50/5090

Mounting surface: ISO 4401-AC-05-4-A

**DIMENSIONS IN
MILLIMETRES (INCHES)**

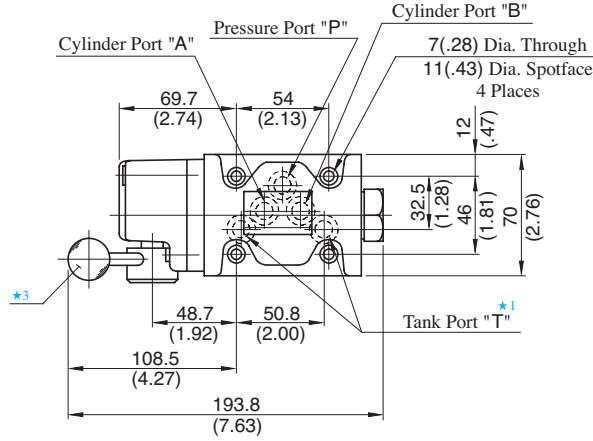

- ★ 1. Although the tank port is shown on the left in our sub-plate either may be used.
- ★ 2. The position of operating lever can be changed as required. For the detail, see the DMT-03 in the [previous page](#).
- ★ 3. Lever Operating Torque:
Not exceeding 30 Nm (266 IN. lbs.)

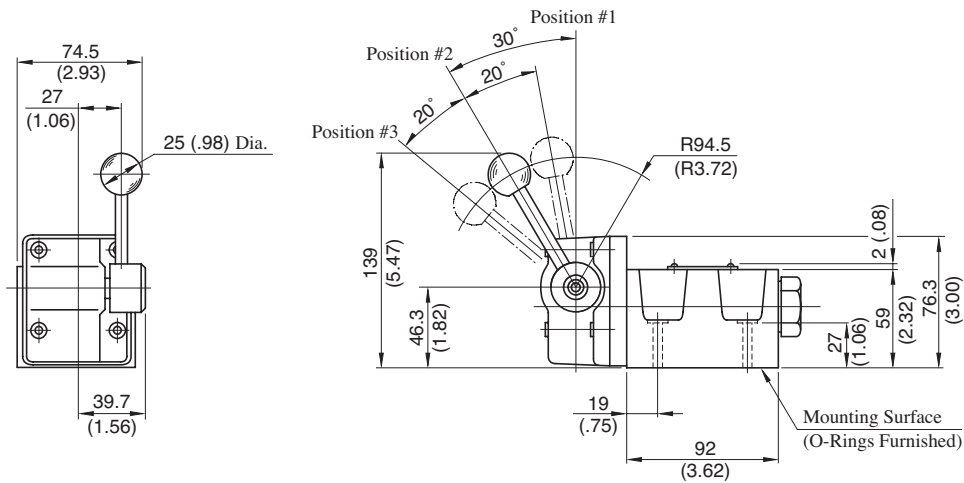

Note: For the valve mounting surface dimensions, see the dimensional drawing of the sharable sub-plate in [page 373](#).

DMG-04-***-21/2190

Mounting surface: ISO 4401-AD-07-4-A

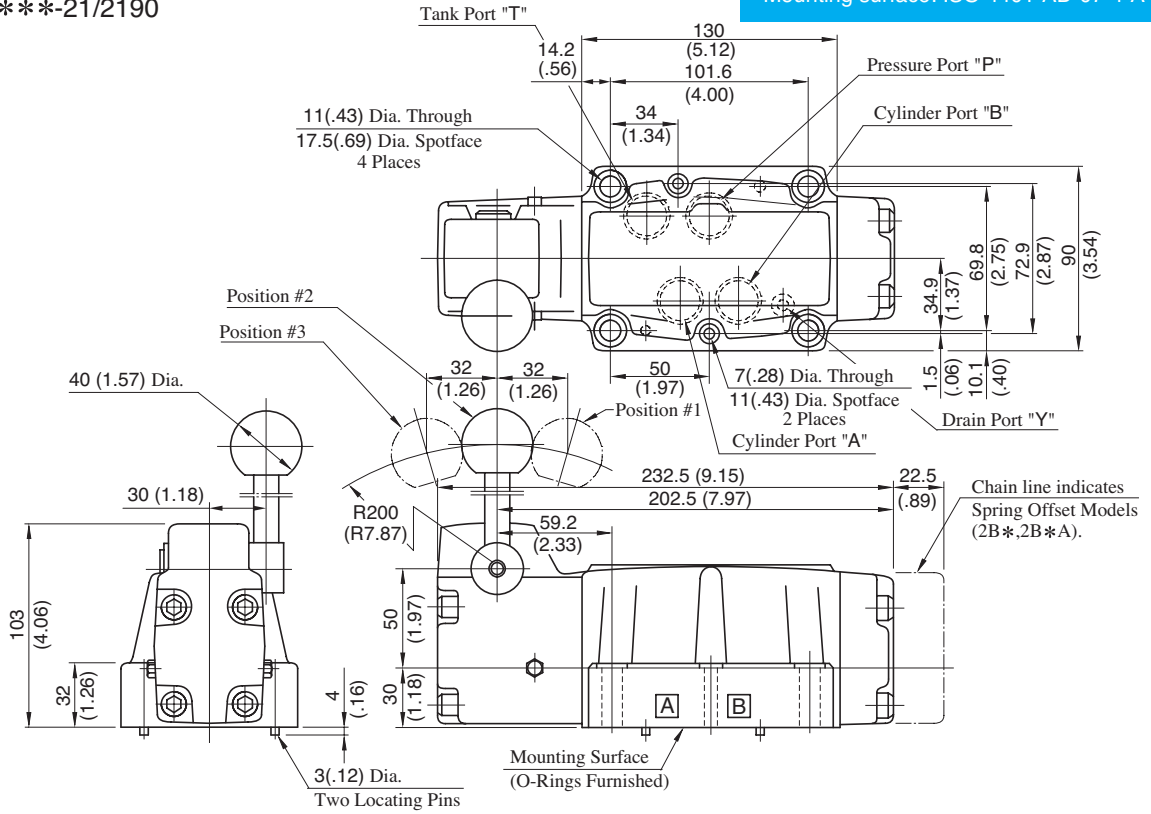

Note: For the valve mounting surface dimensions, see the dimensional drawing of the sharable sub-plate in [page 401](#).

DIMENSIONS IN MILLIMETRES (INCHES)

DMG-06-***-50/5090

Mounting surface: ISO 4401-AE-08-4-A

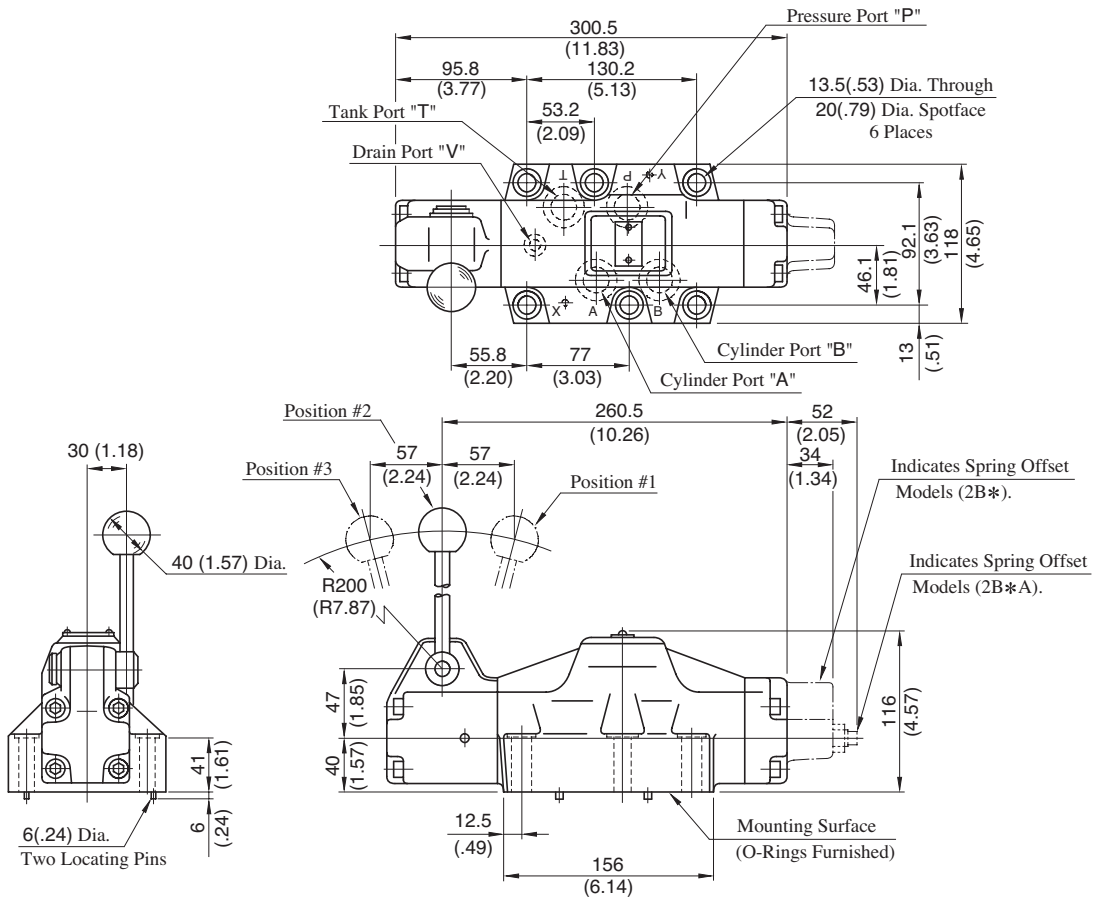

Note: For the valve mounting surface dimensions, see the dimensional drawing of the sharable sub-plate in [page 402](#).



Manually Operated Directional Valves

DMG-10-***-50/5090

Mounting surface: ISO 4401-AF-10-4-A

**DIMENSIONS IN
MILLIMETRES (INCHES)**

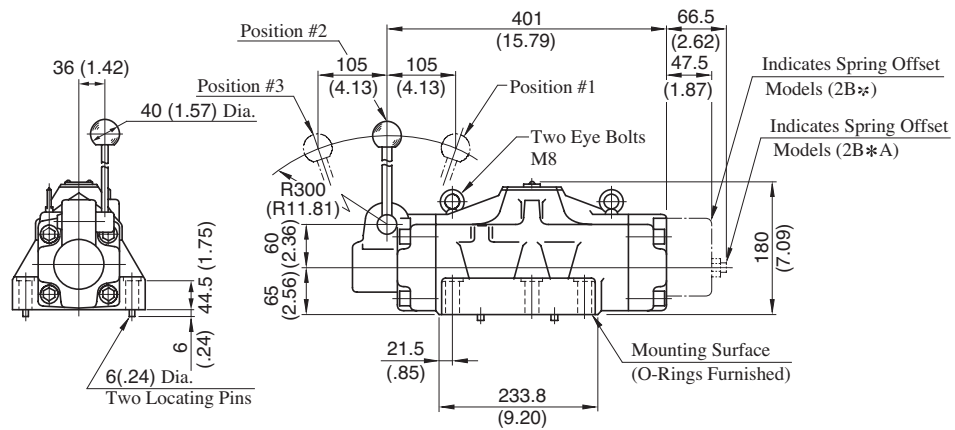
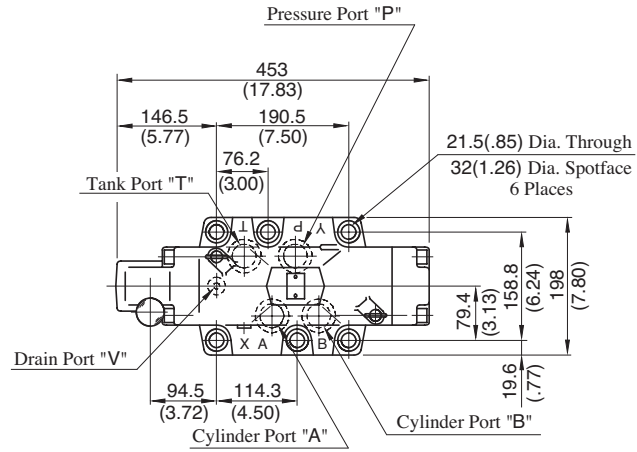

Note: For the valve mounting surface dimensions, see the dimensional drawing of the sharable sub-plate in [page 403](#).

List of Seals

DMG-01-***-10/1090

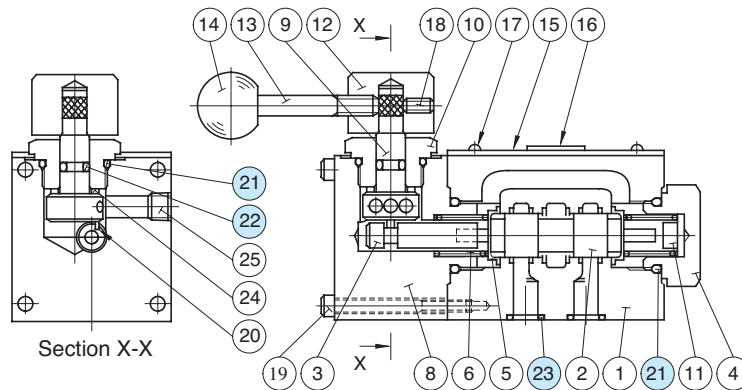

Item	Name of Parts	Part Numbers	Qty.
21	O-Ring	SO-NB-P18	3
22	O-Ring	SO-NA-P6	1
23	O-Ring	SO-NB-P9	4

Note: When ordering the o-ring, please specify the seal kit number (KS-DMG-01-10).

DMT-03-***-50/5080/5090
DMG-03-***-50/5090

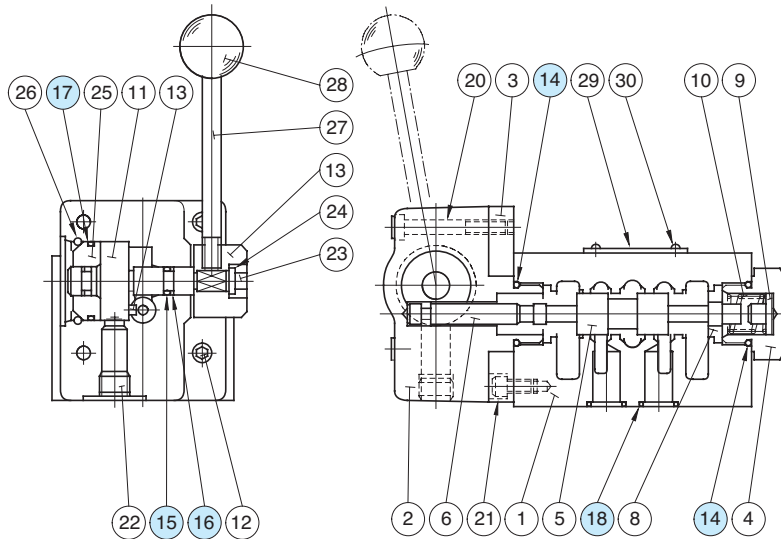

Item	Name of Parts	Part Numbers	Qty.
14	O-Ring	SO-NB-P21	2
15	O-Ring	SO-NA-P8	2
16	Back Up Ring	SO-BB-P8	2
17	O-Ring	SO-NB-A023	1
18	O-Ring	SO-NB-A014	5

Valve Model Numbers	Seal Kit Numbers
DMT-03-***-50/5080/5090	KS-DMT-03-50
DMG-03-***-50/5090	KS-DMG-03-50

- Note: 1. O-rings of Item ⑱ are not used for DMT-03.
2. When ordering the seals, please specify the seal kit number from the table right.

List of Seals

DMT-06, 06X-***-30/3080/3090
 DMT-10, 10X-***-30/3080/3090

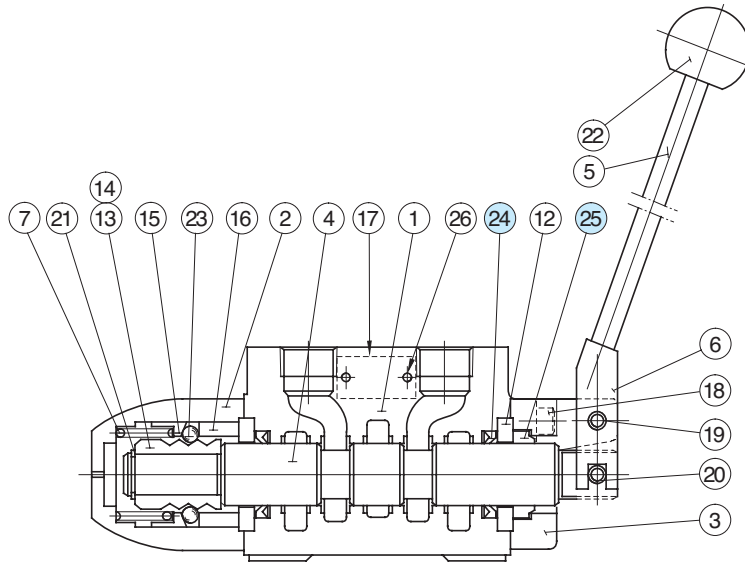

● List of Seal Kits

Item	Name of Parts	Part Numbers		Qty.
		DMT-06*	DMT-10*	
24	Packing	UPI 32 • 40 • 6Y	UPI 40 • 55 • 10Y	2
25	Dust Seal	DKI 32 • 44 • 7 • 10	DKI 40 • 52 • 7 • 10	1

Valve Model Numbers	Seal Kit Numbers
DMT-06*-***-30/3080/3090	KS-DMT-06-30
DMT-10*-***-30/3080/3090	KS-DMT-10-30

Note: When ordering the seals, please specify the seal kit number from the table right.

DMG-04-***-21/2190
 DMG-06-***-50/5090
 DMG-10-***-40/4090

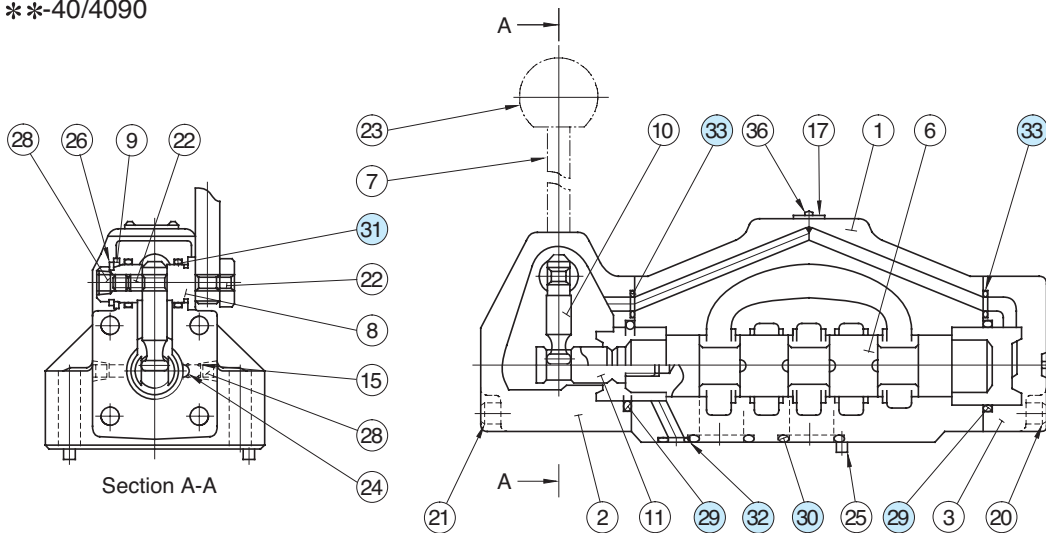

● List of Seal Kits

Item	Name of Parts	Part Numbers			Qty.
		DMG-04	DMG-06	DMG-10	
29	O-Ring	SO-NB-P34	SO-NB-P40	SO-NB-G65	2
30	O-Ring	SO-NB-P22A	SO-NB-P30	SO-NB-P42	4
31	O-Ring	SO-NA-P20	SO-NA-P20	SO-NA-P25	2
32	O-Ring	SO-NB-P9	SO-NB-P14	SO-NB-P20	1
33	O-Ring	SO-NB-P9	SO-NB-P10	SO-NB-P14	2

Valve Model Numbers	Seal Kit Numbers
DMG-04*-***-21/2190	KS-DMG-04-21
DMG-06*-***-50/5090	KS-DMG-06-50
DMG-10-***-40/4090	KS-DMG-10-40

Note: When ordering the seals, please specify the seal kit number from the table right.

Mechanically Operated Directional Valves

These valves are chiefly used to shift the pilot circuit. Rotary Type Directional Valves and Cam Operated Type Directional Valves are available.

Rotary Type Directional Valves

These valves are used to rotate the spool either manually or by way of cam and shift the direction of oil flow. The detented mechanism incorporated in these valves prevents the valve from being changed over by itself due to vibrations or any other shocks.

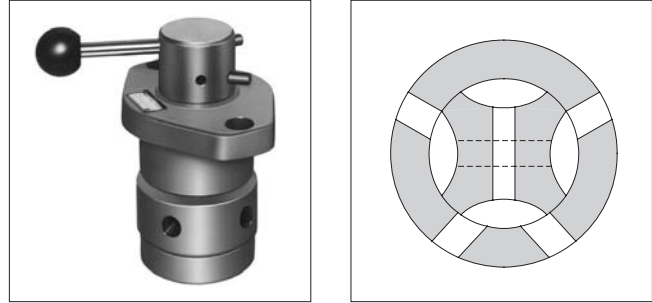

Specifications

Model Numbers		Rated Flow L/min (U.S.GPM)	Max. Operating Pressure MPa (PSI)	Max. T-Line Pressure MPa (PSI)	Approx. Mass kg (lbs.)	
Threaded Connection	Sub-plate Mounting				DRT Type	DRG Type
DRT-02-*D*-20*	DRG-02-*D*-20*	16 (4.2)	7 (1020)	7 (1020)*	4.7 (10.4)	3.4 (7.5)

* When a back pressure of more than 3 MPa (435 PSI) is generated in the tank port, be sure to use External Drain Type.

Model Number Designation

F-	DR	G	-02	-2	D	2	-A	-R	-20	*
Special Seals	Series Connection	Type of Mounting	Valve Size	No. of Valve Position	Spool-Spring Arrangement	Spool Type	Operation Type	Drain Connection	Design Number	Design Standards
F: Special seals for phosphate ester type fluids (Omit if not required)	DR: Rotary Type Directional Valve	T: Threaded Connection	02	2	D: No-spring Detented	2	A: Reversing Dog B: Reversing Dog & Manual C: Manual	None: Intrenal Drain R: External Drain	20	None: Japanese Std. "JIS" 80: European Design Std. 90: N. American Design Std. None: Japanese Std. "JIS" & European Design Std. 90: N. American Design Std.
		G: Sub-plate Mounting	02	3		4			20	

Note: When selecting the Model type, be sure to give the model number from the following Graphic Symbols. No combinations other than those in the table below are allowed.

Graphic Symbols

No. of Position	2-Position Type			3-Position Type
	Reversing Dog Operation	Reversing Dog & Manual Operation	Manual Operation	Manual Operation
Graphic Symbols				
Model No.	DR*-02-2D2-A	DR*-02-2D2-B	DR*-02-2D2-C	DR*-02-3D4-C

Instructions

Changeover Torque

When the pressure of pressure port "P" and cylinder port "A" (or "B") is set to 7 MPa (1020 PSI), the valve changeover torque will be as right side table:

Changeover Torque

Tank Port Back Pres. MPa (PSI)	Torque Nm (in. lbs.)
0	1.0 (8.9)
3 (435)	4.8 (42.5)

2-Way directional valves

Be sure to use the External Drain Type Valve of spool type "2" and plug the tank port.

Sub-plates

Drain Connection	Japanese Standard "JIS"		European Design Standard		N.American Design Standard		Approx. Mass kg (lbs.)
	Sub-plate Model Numbers	Thread Size	Sub-plate Model Numbers	Thread Size	Sub-plate Model Numbers	Thread Size	
For Internal Drain	DRGM-02-20	Rc 1/4	DRGM-02-2080	1/4 BSPF	DRGM-02-2090	1/4 NPT	1.9 (4.2)
	DRGM-02X-20	Rc 3/8	DRGM-02X-2080	3/8 BSPF	DRGM-02X-2090	3/8 NPT	
For External Drain	DRGM-02-R-20	Rc 1/4	DRGM-02-R-2080	1/4 BSPF	DRGM-02-R-2090	1/4 NPT	
	DRGM-02X-R-20	Rc 3/8	DRGM-02X-R-2080	3/8 BSPF	DRGM-02X-R-2090	3/8 NPT	

● Sub-plates are available. Specify the sub-plate model number from the table above. When sub-plates are not used, the mounting surface should have a good machined finish.

Mounting Bolts

The Sub-plate Mounting Type Valves (DRG-02) only are furnished with the following mounting bolts.

Model Numbers	Socket Head Cap Screw (5 Pcs.)	
	Japanese Standard "JIS"	N. American Design Standard
	European Design Standard	
DRG-02	M8 × 45 Lg.	5/16-18 UNC × 1-3/4 Lg.

Pressure Drop

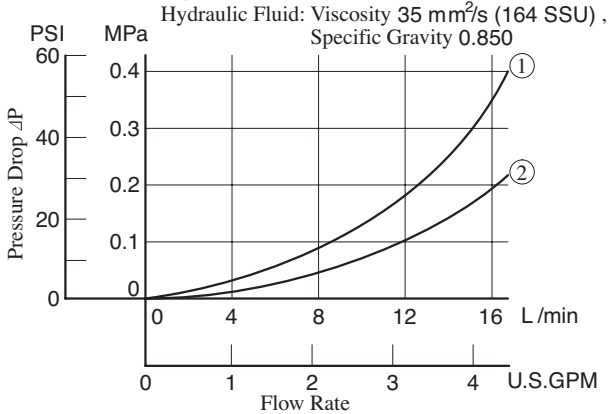

Valve Type	Pressure Drop Curve No.			
	P→A	B→T	P→B	A→T
2D2	②	②	②	②
3D4	②	②	①	②

1. For any other viscosity, multiply by the factors in the table below.

Viscosity	mm ² /s	15	20	30	40	50	60	70	80	90	100
	SSU		77	98	141	186	232	278	324	371	417
Factor		0.81	0.87	0.96	1.03	1.09	1.14	1.19	1.23	1.27	1.30

2. For any other specific gravity (G'), the pressure drop (ΔP) may be obtained from the formula below.

$$\Delta P' = \Delta P (G'/0.850)$$

DRT-02- *D* - *-20/2080/2090

● Type "A" : Reversing Dog Operation

● Type "B": Reversing Dog and Manual Operation

● Type "C": Manual Operation

Model Numbers	"C" Thd.
DRT-02- *D* - *-20	Rc 1/4
DRT-02- *D* - *-2080	1/4 BSPF
DRT-02- *D* - *-2090	1/4 NPT

DIMENSIONS IN MILLIMETRES (INCHES)

For other dimensions, refer to "Reversing Dog Operation".

DRG-02-*D*-*20/2090

● Type "A": Reversing Dog Operation

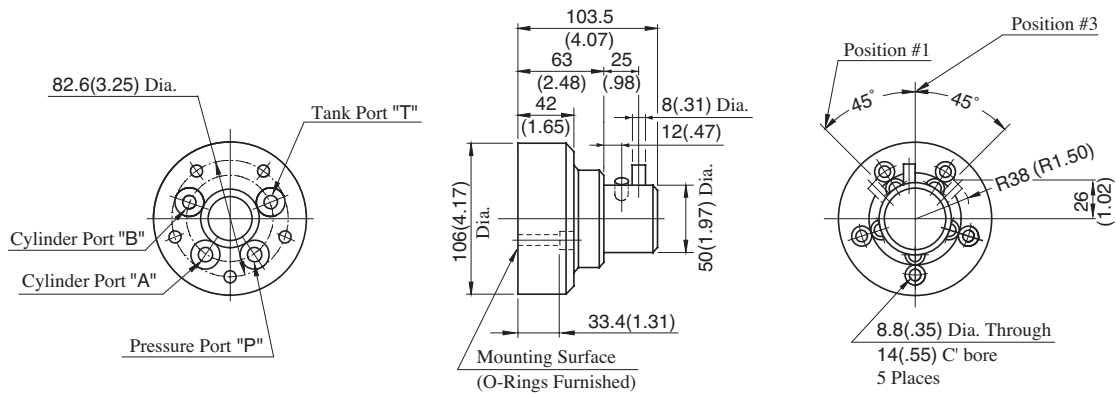

For information on Type "B": reversing Dog and Manual Operation and Type "C": Manual Operation, see DRT-02 on the [previous page](#).

**DIMENSIONS IN
MILLIMETRES (INCHES)**

Sub-plates : DRGM-⁰²_{02X}-*20/2080/2090

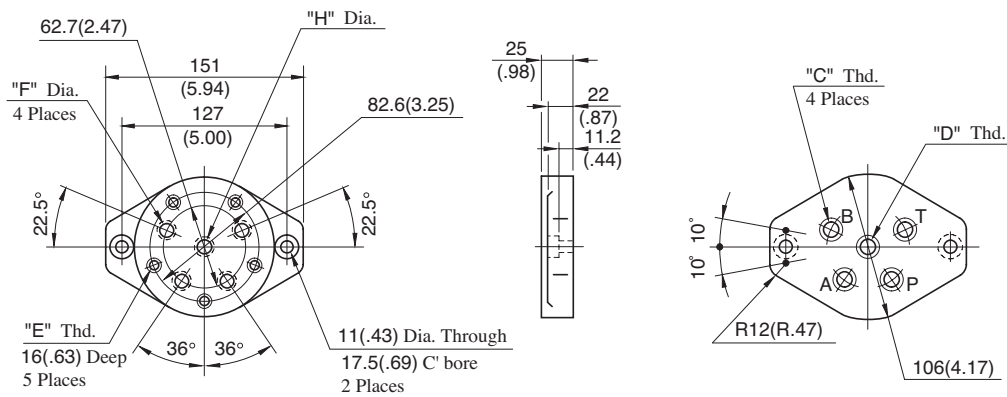

Sub-plate Model Numbers	"C" Thd.	"D" Thd.	"E" Thd.	mm (Inches)		Remarks
				F	H	
DRGM-02-20 DRGM-02X-20	Rc 1/4 Rc 3/8	—	M8	11 (.43)	—	For Internal Drain
DRGM-02-2080 DRGM-02X-2080	1/4 BSP.F 3/8 BSP.F	—	M8	11.7 (.46)	—	
DRGM-02-2090 DRGM-02X-2090	1/4 NPT 3/8 NPT	—	5/16-18 UNC	11 (.43)	—	
DRGM-02-R-20 DRGM-02X-R-20	Rc 1/4 Rc 3/8	Rc 1/4	M8	11 (.43)	11 (.43)	For External Drain
DRGM-02-R-2080 DRGM-02X-R-2080	1/4 BSP.F 3/8 BSP.F	1/4 BSP.F	M8	11.7 (.46)	11.7 (.46)	
DRGM-02-R-2090 DRGM-02X-R-2090	1/4 NPT 3/8 NPT	1/4 NPT	5/16-18 UNC	11 (.43)	11 (.43)	



■ List of Seals

DRT-02- *D* - *-20/2080/2090

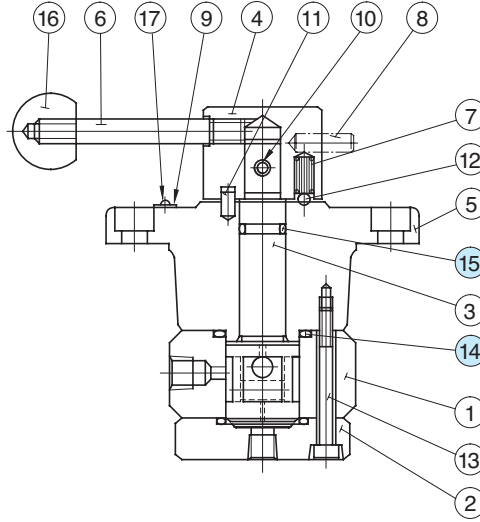

Item	Name of Parts	Part Numbers	Qty.	Remarks
14	O-Ring	SO-NB-G35	2	Included in Seal Kit
15	O-Ring	SO-NA-P16	1	(Kit No.: KS-DRT-02-20)

DRG-02- *D* - *-20/2090

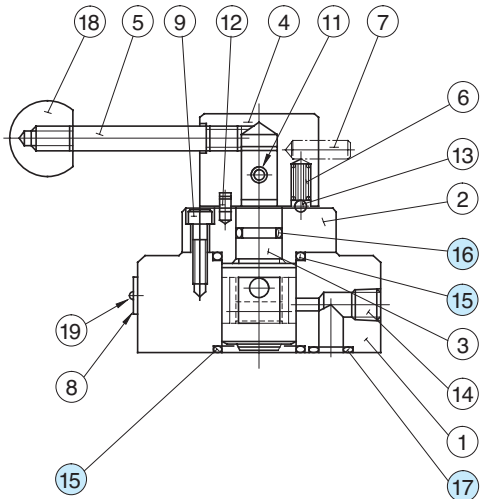

Item	Name of Parts	Part Numbers	Qty.	Remarks
15	O-Ring	SO-NB-G35	2	Included in Seal Kit (Kit No.: KS-DRG-02-20)
16	O-Ring	SO-NA-P16	1	
17	O-Ring	SO-NB-P16	4	