

Pilot Operated Directional Valves

These valves perform a change over of spool by hydraulic pilot and shift the direction of oil flow.

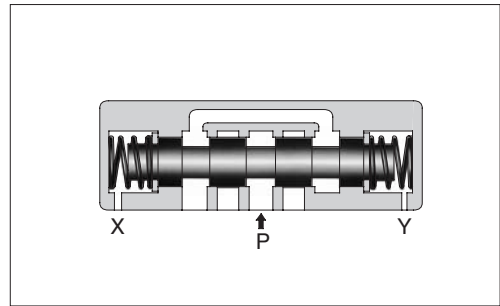
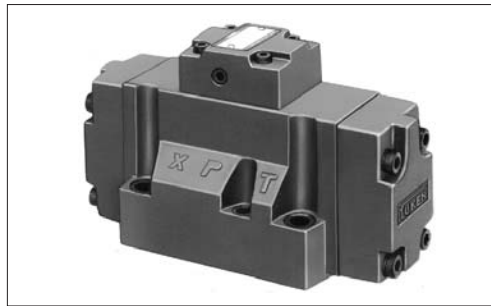

Specifications

Model Numbers	Maximum Flow L/min (U.S.GPM)				Max. Operating Pressure MPa (PSI)	Max. Pilot Pressure MPa (PSI)	Min. Required Pilot Pressure MPa (PSI)	Max. T-Line Back Pressure MPa (PSI)	Approx. Mass kg (lbs.)
	10 MPa (1450 PSI)	16 MPa (2320 PSI)	25 MPa (3630 PSI)	31.5 MPa (4570 PSI)					
DHG-04-3C*-50*	300 (79.3) ^{*1}	300 (79.3) ^{*1}	300 (79.3) ^{*1}	300 (79.3) ^{*1}	31.5 (4570)	25 (3630)	0.8 (120)	21 (3050)	7.4 (16.3)
DHG-04-2N*-50*	300 (79.3)	300 (79.3)	300 (79.3)	300 (79.3)					7.4 (16.3)
DHG-04-2B*-50*	130 (34.3)	70 (18.5)	70 (18.5)	60 (15.9)					7.8 (17.2)
DHG-06-3C*-50*	500 (132) ^{*2}	500 (132) ^{*2}	500 (132) ^{*2}	500 (132) ^{*2}	31.5 (4570)	25 (3630)	0.8 (120) ^{*4}	21 (3050)	11.2 (24.7)
DHG-06-2N*-50*	500 (132)	500 (132)	500 (132)	500 (132)					11.2 (24.7)
DHG-06-2B*-50*	140 (37)	100 (26.4)	90 (23.8)	80 (21.1)					11.7 (25.8)
DHG-06-3H*-50*	500 (132)	500 (132)	500 (132)	500 (132) ^{*3}					12.0 (26.5)
DHG-10-3C*-40*	1100 (291) ^{*3}	1100 (291) ^{*3}	1100 (291) ^{*3}	1100 (291) ^{*3}	31.5 (4570)	25 (3630)	1 (150) ^{*4}	21 (3050)	43.8 (96.6)
DHG-10-2N*-40*	1100 (291)	1100 (291)	1100 (291)	1100 (291)					43.8 (96.6)
DHG-10-2B*-40*	460 (122)	300 (79.3)	220 (58.1)	200 (52.8)					45.6 (101)
DHG-10-3H*-40*	1100 (291)	1100 (291)	1100 (291) ^{*3}	1100 (291) ^{*3}					51.6 (114)

Note: Max. flow in the table above represents the value in the flow condition of P→A →B→T (or P→B→A→T) as shown in the circuit diagram right.

In case the valves is used in the condition that either A or B port is blocked, the maximum flow differs according to a hydraulic circuit, therefore, please consult us for details.

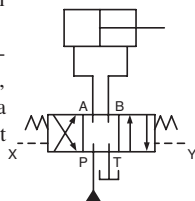

- ★ 1. Varies depending on the spool type. For more information, see page 388 for the List of “Standard Model and Maximum Flow” (DSHG-04) for Solenoid Controlled Pilot Operated Directional Valves.
- ★ 2. Varies depending on the spool type and pilot pressure. For more information, see page 389 for the List of “Standard Model and Maximum Flow” (DSHG-06) related to the Solenoid Controlled Pilot Operated Directional Valves.
- ★ 3. Varies depending on the spool type and pilot pressure. For more information, see page 390 for the List of “Standard Model and Maximum Flow” (DSHG-10) related to the Solenoid Controlled Pilot Operated Directional Valves.
- ★ 4. Minimum Pilot Pressure for the models with pilot piston is 1.8 MPa (260 PSI).

Yuken can offer flanged connection valves described below.
Consult us for the details.

Model Numbers	Rated Flow L/min (U.S.GPM)	Max. Operating Pres. MPa (PSI)
DHF-16-***-30*	500 (132)	21 (3050)
DHF-24-***-26*	1200 (317)	
DHF-32-***-21*	2400 (634)	

Pressure Drop

Same as those for Solenoid Controlled Pilot Operated Directional Valves. See pages 392 and 393 for the related information.

Instruction

- In case of Spring Offset Models, directly connect the pilot pressure port "Y" to the reservoir as a drain port.

Model Number Designation

F-	DH	G	-04	-2	B	2	A	-C2	-RA	-H	-50	*		
Special Seals	Series Number	Type of Connection	Valve Size	Number of Valve Positions	Spool-Spring Arrangement	Spool Type	Special Two Position Valve	Model with Pilot Choke Valve (Options) ^{★2}	Spool Control Modification (Options) ^{★2}	Built-in Orifice for Pilot Line	Design Number	Design Standard		
F: Special Seals for Phosphate ester type fluids (Omit if not required)	DH: Pilot Operated Directional Valve	G: Sub-plate Mounting	04	3	C: Spring Centred	2, 3 4, 40 5, 6 60, 7 9, 10 11, 12	A ^{★3} , B ^{★3} (Omit if not required)	C2: With C2 Choke	R2: With Stroke Adjustment, Both Ends RA: With Stroke Adjustment, Port A End RB: With Stroke Adjustment, Port B End P2: With Pilot Piston, Both Ends PA: With Pilot Piston, Port A End PB: With Pilot Piston, Port B End	—	50	Refer to ^{★5}		
			06		H: Pressure Centred (Option) ^{★2}								H: Refer to ^{★4}	50
			10		N: No-Spring B: Spring Offset									
Refer to ^{★1}														

- ★1. For various combination, see the List of Valve Types below.
- ★2. For the option combinations of the Type (Valve Size) and Options, see the List of Options below.
- ★3. Refer to the column "valves using neutral position and side position" (Special 2-position valve) on page 426.
- ★4. In spool-spring arrangement "H" (pressure centred models), in case the pilot pressure is more than 10 MPa (150PSI), please specify that the valve should have the built-in orifice to the pilot line.
- ★5. Design Standards: None..... Japanese Standard "JIS" and European Design Standard 90..... N. American Design Standard

List of Valve Type

Spool Type	Valve Types			
	Three Positions		Two Positions	
	Spring Centred	Pressure [★] Centred	No-Spring	Spring Offset
	Graphic Symbols			
2				
3				
4				
40				
5				
6				
60				
7				
9				
10				
11				
12				

★: Pressure Centered Models are not available for the Valve Size of "04".

List of Options

Model Numbers	Option Code							
	3H*	C2	R2	RA	RB	P2	PA	PB
DHG-04-3C*	×	○	○	○	○	×	×	×
DHG-04-2N*	×	○	○	○	○	×	×	×
DHG-04-2B*	×	○	×	○	×	×	×	×
DHG-06-3C*	×	○	○	○	○	○	○	○
DHG-06-2N*	×	○	○	○	○	○	○	○
DHG-06-2B*	×	○	×	○	×	×	○	×
DHG-06-3H*	○	○	×	×	×	×	×	×
DHG-10-3C*	×	○	○	○	○	○	○	○
DHG-10-2N*	×	○	○	○	○	○	○	○
DHG-10-2B*	×	○	×	○	×	×	○	×
DHG-10-3H*	○	○	×	×	×	×	○	×

Note. ○ Mark: Available
× Mark: Not Available

Sub-plate

Valve Model Numbers	Japanese Standard "JIS"			European Design Standard			N. American Design Standard		
	Sub-plate Model Numbers	Thread Size	Approx. Mass kg (lbs.)	Sub-plate Model Numbers	Thread Size	Approx. Mass kg (lbs.)	Sub-plate Model Numbers	Thread Size	Approx. Mass kg (lbs.)
DHG-04	DHGM-04-20	Rc 1/2	4.4 (9.7)	DHGM-04-2080	1/2 BSP.F	4.4 (9.7)	DHGM-04-2090	1/2 NPT	4.4 (9.7)
	DHGM-04X-20	Rc 3/4	4.1 (9.0)	DHGM-04X-2080	3/4 BSP.F	4.1 (9.0)	DHGM-04X-2090	3/4 NPT	4.1 (9.0)
DHG-06	DHGM-06-50	Rc 3/4	7.4 (16.3)	DHGM-06-5080	3/4 BSP.F	8.5 (18.7)	DHGM-06-5090	3/4 NPT	7.4 (16.3)
	DHGM-06X-50	Rc 1	7.4 (16.3)	DHGM-06X-5080	1 BSP.F	8.5 (18.7)	DHGM-06X-5090	1 NPT	7.4 (16.3)
DHG-10	DHGM-10-40	Rc 1-1/4	21.5 (47.4)	DHGM-10-4080	1-1/4 BSP.F	21.5 (47.4)	DHGM-10-4090	1-1/4 NPT	21.5 (47.4)
	DHGM-10X-40	Rc 1-1/2	21.5 (47.4)	DHGM-10X-4080	1-1/2 BSP.F	21.5 (47.4)	DHGM-10X-4090	1-1/2 NPT	21.5 (47.4)

- Sub-plates are available. Specify the sub-plate model number from the table above. When sub-plates are not used, the mounting surface should have a good machined finish.
- Sub-plates are shared with those for Solenoid Controlled Pilot Operated Directional Valves. Refer to [pages 401 to 403](#) for dimensions.

Mounting Bolts

Model Numbers	Socket Head Cap Screw			
	Japanese Standard "JIS" European Design Standard	N. American Design Standard	Qty.	Tightening Torque Nm (in. lbs)
DHG-04	M6 × 45 Lg.	1/4-20 UNC × 1-3/4 Lg.	2	12-15 (106-133)
	M10 × 50 Lg.	3/8-16 UNC × 2 Lg.	4	58-72 (513-637)
DHG-06	M12 × 60 Lg.	1/2-13 UNC × 2-1/2 Lg.	6	100-123 (885-1089)
DHG-10	M20 × 75 Lg.	3/8-16 UNC × 2 Lg.	6	473-585 (4186-5177)

Options

Models with Pilot Choke Adjustment (C2)

When the adjustment screw is turned clockwise, changeover speed of the spool becomes slow. In case of the spring centred valves in particular, making slow of the returning speed of the spool to the neutral position is possible with a C2 choke valve. These choke valves can be used in combination with valves of spring centred, no spring, spring offset, pressure centred and the valves with stroke adjustment.

Graphic Symbols
Spring Centred Models

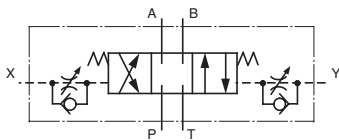

Pressure Centred Models (3H*)

The pressure centred type can be used when the returning of the spool to the neutral position is required to be done firmly.

Graphic Symbol

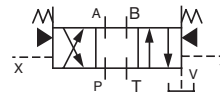

Models with Stroke Adjustment (R*)

When the adjustment screw is screwed in, the spool stroke becomes short and flow rate reduces

Graphic Symbol

Spring Centred Models with Stroke Adjustment on Both Ends (R2)

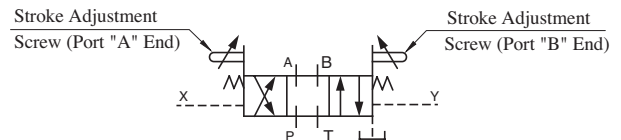

Models with Pilot Piston (P*)

The valves with a pilot piston can be used when the high speed changeover of the spool is required. However, please note that in case of spring centred valves, there is no change in the returning speed of the spool to the neutral position even with the pilot piston.

Graphic Symbols

Spring Centred Models with Pilot Piston on Both Ends (P2)

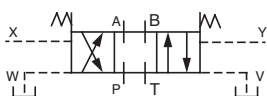

Spring Centred Models with Pilot Piston on Port "A" End (PA)

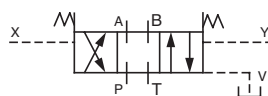

Additional Mass of Options

Add the mass described below to the mass of standard models on [page 423](#) if options are required.

Model Numbers	With Pilot Choke Valve	With Pilot Piston		With Stroke Adjustment	
		P2	PA PB	R2	RA RB
DHG-04	0.65 (1.4)	—	—	1.0 (2.2)	0.5 (1.1)
DHG-06	0.65 (1.4)	1.0 (2.2)	0.5 (1.1)	1.2 (2.6)	0.6 (1.3)
DHG-10	0.65 (1.4)	3.6(7.9)	1.8 (4.0)	3.7 (8.2)	1.85 (4.1)

Valves Using Neutral Position and Side Position (Special Two Position Valve)

In addition to the standard two positions valves (2B*), the following two types of two positions valves are available: valves with neutral position and pilot Y pressure position (2B* A), valves with neutral position and pilot X pressure position (2B* B).

Model Numbers	Graphic Symbols	Model Numbers	Graphic Symbols
04 DHG-06-2B* <u>A</u> 10		04 DHG-06-2B* <u>B</u> 10	
DHG-*-2B2A		DHG-*-2B2B	
DHG-*-2B3A		DHG-*-2B3B	
DHG-*-2B4A		DHG-*-2B4B	
DHG-*-2B40A		DHG-*-2B40B	
DHG-*-2B5A		DHG-*-2B5B	
DHG-*-2B6A		DHG-*-2B6B	
DHG-*-2B60A		DHG-*-2B60B	
DHG-*-2B7A		DHG-*-2B7B	
DHG-*-2B9A		DHG-*-2B9B	
DHG-*-2B10A		DHG-*-2B10B	
DHG-*-2B11A		DHG-*-2B11B	
DHG-*-2B12A		DHG-*-2B12B	

DHG-04-*-50/5090**

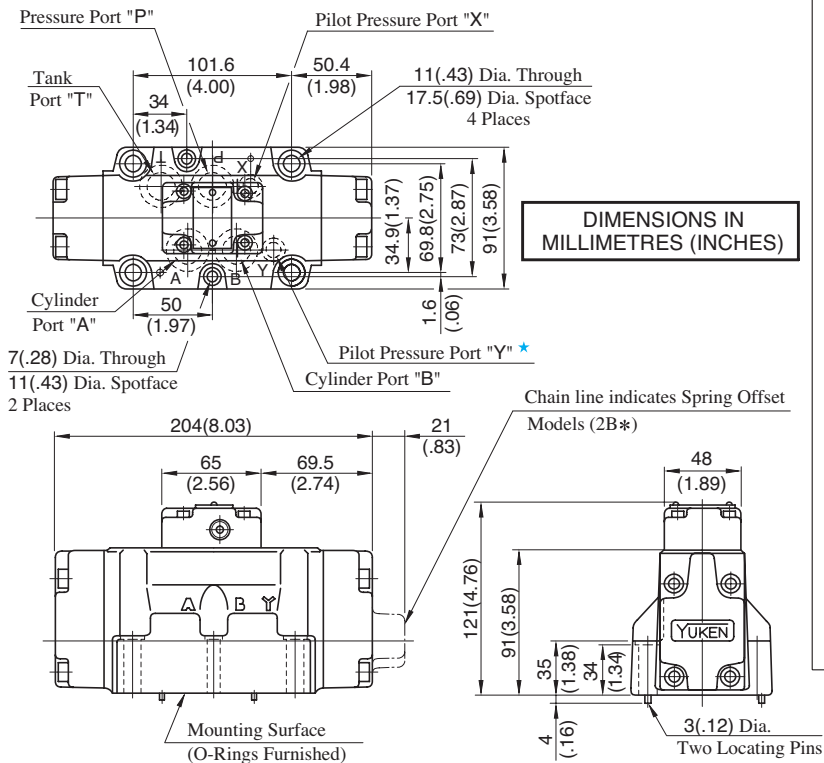

Note: For the valve mounting surface dimensions, see the dimensional drawing of the sharable sub-plate on page 401.

Mounting Surface: ISO 4401-AD-07-4-A

Options

● **Models with Pilot Choke Valve**

DHG-04-***-C2

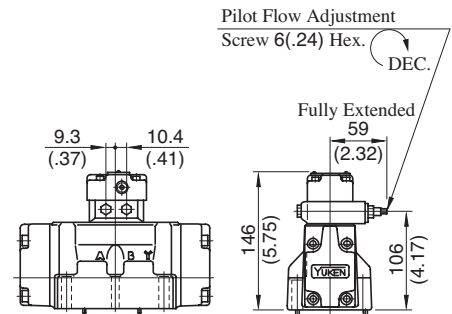

● **Models with Stroke Adj. (R*)**

Outside dimensions are the same as those of the main valve of Solenoid Controlled Pilot Operated Directional Valves (DSHG-04). See page 405.

★ For Spring Offset Models (2B*, 2B*A), it functions as drain port. When that model is used, directly connect it to the reservoir.

DHG-06-***-50/5090

Mounting surface: ISO 4401-AE-08-4-A

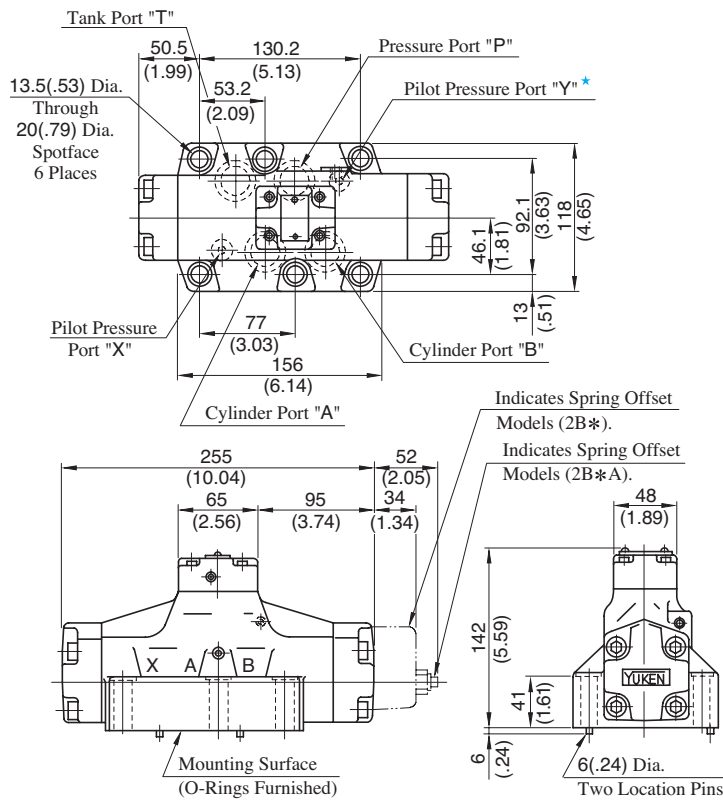

Note: For the valve mounting surface dimensions, see the dimensional drawing of the sharable sub-plate in [page 402](#).

Options

- **Models with Pilot Choke Valve**
DHG-06-***-C2

Pilot Flow Adjustment Screw

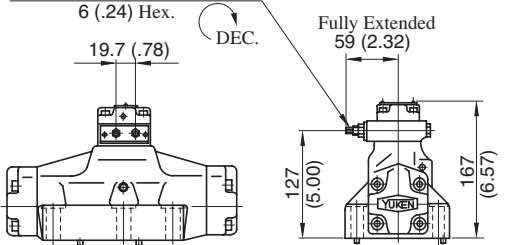

- **Pressure Centred Models (3H*)**
- **Models with Stroke Adjustment (R*)**
- **Models with Pilot Piston (P*)**

The outside dimensions of the above options are the same as those of the main valve of Solenoid Controlled Pilot Operated Directional Valve (DSHG-06). See [page 405](#).

★ In case of Spring Offset Model (2B*, 2B*^A/_B), it functions as a drain port. When that model is used, directly connect it to the reservoir.

DIMENSIONS IN MILLIMETRES (INCHES)

DHG-10-***-40/4090

Mounting surface: ISO 4401-AF-10-4-A

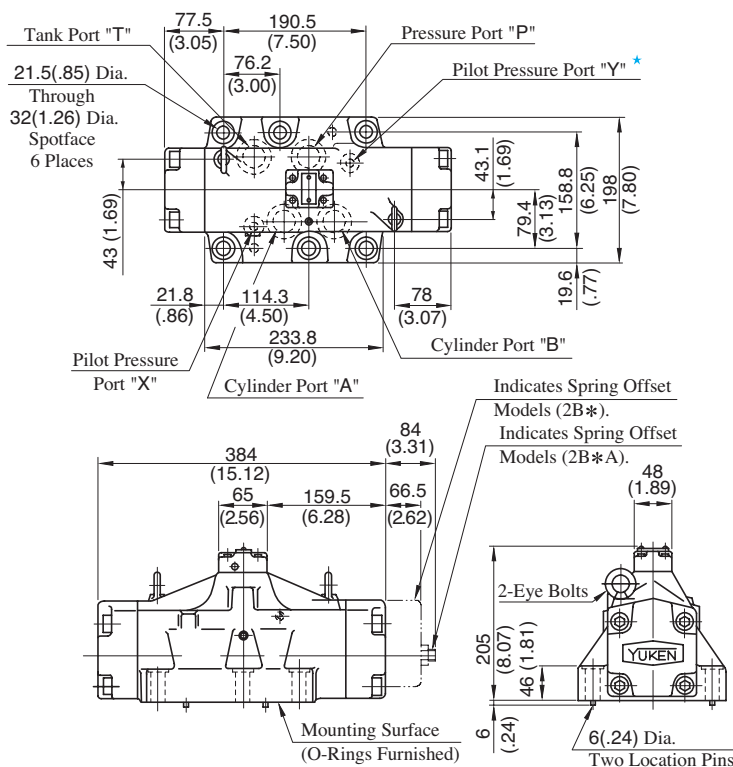

Note: For the valve mounting surface dimensions, see the dimensional drawing of the sharable sub-plate in [page 403](#).

Options

- **Models with Pilot Choke Valve**
DHG-10-***-C2

Pilot Flow Adjustment Screw

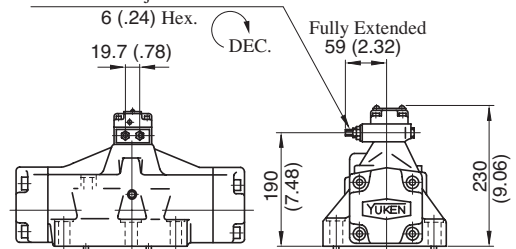

- **Pressure Centred Models (3H*)**
- **Models with Stroke Adjustment (R*)**
- **Models with Pilot Piston (P*)**

The outside dimensions of the above options are the same as those of the main valve of Solenoid Controlled Pilot Operated Directional Valves (DSHG-10). See [page 405](#).

★ In case of Spring Offset Model (2B*, 2B*^A/_B), in functions as a drain port. When that model is used, directly connect it to the reservoir.



■ List of Seals

DHG-04-***-50/5090

DHG-06-***-50/5090

DHG-10-***-40/4090

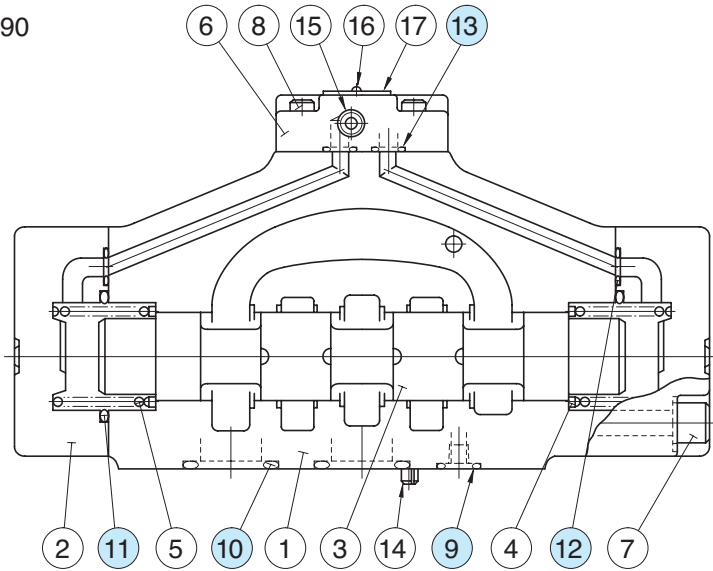

Item	Name of Parts	Part Numbers			Qty
		DHG-04	DHG-06	DHG-10	
9	O-Ring	SO-NB-P9	SO-NB-P14	SO-NB-P20	2
10	O-Ring	SO-NB-P22	SO-NB-P30	SO-NB-P42	4
11	O-Ring	SO-NB-P34	SO-NB-P40	SO-NB-G65	2
12	O-Ring	SO-NB-P9	SO-NB-P10	SO-NB-P14	2
13	O-Ring	SO-NB-P9	SO-NB-P9	SO-NB-P9	4

Note: When ordering the o-rings, please specify the seal kit number from the table below.

Valve Model Numbers	Seal Kit Numbers
DHG-04-***-50/5090	KS-DHG-04-50
DHG-06-***-50/5090	KS-DHG-06-50
DHG-10-***-40/4090	KS-DHG-10-40